

Chemical Nomenclature

Naming and Writing Chemical Formulas

VOCABULARY

Ion — an atom or group of atoms that has gained or lost electrons

Monatomic ion — an atom that has gained or lost electrons and has a charge

Polyatomic ion — a group of covalently bound atoms that has a charge

Anion — a negatively charged ion

Cation — a positively charged ion

Charge — the positive or negative value assigned to an ion as a result of having lost or gained electrons

Oxidation number — hypothetical charge a covalently bound atom would have IF its bonds were ionic

Acid — a compound that donates a H^+ ion during a reaction

Ionic compound — a compound made of positively and negatively charged ions

Molecular compound — a compound held together by shared pairs of electrons

Hydrocarbon — a compound composed of carbon and hydrogen

Alcohol — a hydrocarbon that has had one or more of its hydrogens replaced with $-OH$ groups

"
"
"

INTRODUCTION

Writing chemical formulas will open your eyes to the chemical world. Once you are able to write correct chemical formulas there are four naming systems you will need to master. The trick lies in recognizing *which* naming system to use! Use the following guidelines when making your decisions about how to name compounds.

- If the chemical formula for the compound starts with H, it is an acid. Use the Naming Acids rules.
- If the chemical formula for the compound starts with C and contains quite a few H's and perhaps some O's, it is organic. Use the Naming Organic Compounds rules.
- If the chemical formula for the compound starts with a metal it is most likely ionic. Use the Naming Binary Ionic Compounds rules.
- If the chemical formula for the compound starts with a nonmetal other than H or C, use the Naming Binary Molecular Compounds rules.

It is *essential* that you memorize at least 9 common polyatomic ions. Polyatomic ions are groups of atoms that behave as a unit and possess an overall charge. *If more than one copy of a polyatomic ion is needed to create a chemical formula, the ion must be enclosed in parentheses before adding the subscripts.* You need to know their names, formulas and charges. If you learn the nine that follow, you can determine the formula and charges for many others from applying two simple patterns.

Name of Polyatomic Ion:	Formula & Charge:
Ammonium ion	NH_4^+
Acetate ion	$\text{C}_2\text{H}_3\text{O}_2^-$
Cyanide ion	CN^-
Hydroxide ion	OH^-
Nitrate ion	NO_3^-
Chlorate ion	ClO_3^-
Sulfate ion	SO_4^{2-}
Carbonate ion	CO_3^{2-}
Phosphate ion	PO_4^{3-}

Pattern 1: The -ates “ate” one more oxygen than the -ites **however**, their charge does not change as a result. For instance, if you know nitrate is NO_3^- , then nitrite must be NO_2^- . If you know phosphate is PO_4^{3-} , then phosphite must be PO_3^{3-} . You can also use the prefixes *hypo-* and *per-* with the chlorate series. Perchlorate, ClO_4^- , was really “*hyper and -ate yet another oxygen*” when compared to chlorate, ClO_3^- . Hypochlorite is a double whammy. It is -ite and therefore “ate” one less oxygen than chlorate **and** it is hypo- which means “below” so it “ate” even one less oxygen than plain chlorite so its formula must be ClO^- . You can substitute the other halogens for chlorine and make similar sets of this series.

Pattern 2: The -ates with charges less than negative one, meaning ions with charges of -2 , -3 , etc., can have an H added to them to form new polyatomic ions. For each H added the charge is increased by a $+1$. For instance, CO_3^{2-} can have an H added and become HCO_3^- . HCO_3^- is called either the bicarbonate ion or the hydrogen carbonate ion. Since phosphate is negative three, you can add one or two hydrogens to make new polyatomic ions, HPO_4^{2-} and H_2PO_4^- . The names are hydrogen phosphate and dihydrogen phosphate, respectively. If you continue adding hydrogen ions until you reach neutral, you’ve made an acid! That means you need to see the Naming Acids rules.

NAMING ORGANIC COMPOUNDS

How do I know it is organic? The chemical formula will start with a C followed by hydrogens and may even contain some oxygen. Most of the organic carbons you will encounter will be either hydrocarbons or alcohols. These are the simplest of all to name. Memorize the list of prefixes in Table B found in the conclusion questions. The prefixes correspond to the number of carbons present in the compound and will be the stem for each organic compound. Notice that the prefixes are standard geometric prefixes once you pass the first four carbons. This silly statement will help you remember the order of the first four prefixes: “Me Eat Peanut Butter.” This corresponds to meth-, eth-, prop-, and but- which correspond to 1, 2, 3, and 4 carbons, respectively. Now that we have a stem, we need an ending. There are three common hydrocarbon endings that you will need to know as well as the ending for alcohols. The ending changes depending on the structure of the molecule.

- **-ane** - alkane (all single bonds & saturated) C_nH_{2n+2} ; The alkanes are referred to as saturated hydrocarbons because they contain only single bonds and thus, the maximum number of hydrogen atoms.
- **-ene** = alkene (contains one double bond & unsaturated) C_nH_{2n} ; The alkenes are referred to as unsaturated hydrocarbons because a pair of hydrogens have been removed to create the double bond.
- **-yne** \equiv alkyne (contains one triple bond & unsaturated) C_nH_{2n-2} ; The alkynes are also referred to as unsaturated, because two pairs of hydrogens have been removed to create the triple bond. The term polyunsaturated means that the compound contains more than one double or triple bond.
- **-ol** – alcohol (one H is replaced with a hydroxyl group, -OH group, to form an alcohol) $C_nH_{2n+1}OH$; Do not be fooled—this looks like a hydroxide ion, but is not! It does not make this hydrocarbon an alkaline or basic compound. Do not name these as a hydroxide! C_2H_6 is ethane while C_2H_5OH is ethanol.

NAMING BINARY IONIC COMPOUNDS

How do I know it is ionic? The chemical formula will begin with a metal cation (+ ion) or the ammonium cation. The ending is often a polyatomic anion. If only two elements are present, they are usually from opposite sides of the periodic table, like KCl. If the metal can have more than one oxidation state, be prepared to use a Roman numeral indicating which oxidation state the metal is exhibiting. Group IA alkali metals, Group IIA alkaline earth metals, aluminum (Al), silver (Ag), cadmium (Cd) and zinc (Zn) are exceptions to the Roman numeral rule because their charges are constant. Group IA metals are always +1, Group IIA metals are always +2, Al is always +3, Ag is always +1, and Cd and Zn are always +2 in chemical compounds.

In order to name these compounds, first name the ions.

Naming positive ions: Metals commonly form cations.

- Monatomic positive ions in Group A are named by simply writing the name of the metal from which it is derived. Al^{3+} is the aluminum ion.
- Metals often form more than one type of positive ion so Roman numerals (in parentheses) follow the ion's name. Cu^{2+} is the copper(II) ion. Remember the exceptions — IA, IIA, Al, Ag, Cd, Zn.
- NH_4^+ is the ammonium ion. It is the only positive polyatomic ion that you will encounter.

Naming negative ions: Nonmetals commonly form anions (– ions). Most of the polyatomic ions are also negatively-charged.

- Monatomic negative ions are named by adding the suffix -ide to the stem of the nonmetal's name. Group VIIA, the Halogens are called the halides. Cl^- is the chloride ion.
- Polyatomic anions are given the names of the polyatomic ion. You must memorize these as instructed. NO_2^- is the nitrite ion.

Naming the Compound: The + ion (cation) name is given *first* followed by the name of the negative ion (anion). Remember, to include the Roman numeral that indicates a metal's charge for the many metals that have more than one oxidation state. **No prefixes are used in naming ionic compounds.**

NAMING BINARY MOLECULAR COMPOUNDS

How will I know it is a molecular compound? The chemical formula will contain a combination of nonmetals, both lying near each other on the periodic table. No polyatomic ions will be present. Use the following set of prefixes when naming molecular compounds.

Subscript	Prefix
1	Mono- [usually used only on the second element; such as carbon monoxide or nitrogen monoxide]
2	di-
3	tri-
4	tetra-
5	penta-
6	hexa-
7	hepta-
8	octa-
9	nona-
10	deca-

Naming the Compound: The name of the element with the positive oxidation state is given *first*, followed by the name of the element with the negative oxidation state. Use prefixes to indicate the number of atoms of each element. Don't forget the -ide ending. If the second element's name begins with a vowel, then the "a" at the end of the prefix is usually dropped. N_2O_5 is dinitrogen pentoxide not dinitrogen pentaoxide. PCl_5 is phosphorous pentachloride not phosphorous pentchloride.

FORMULA WRITING

Naming is the trickiest part! Once you have been given the name, the formula writing is easy *as long as you have memorized the formulas and charges of the polyatomic ions*. The prefixes of a molecular compound make it really easy to write the formula since the prefix tells you how many atoms are present for each element. Roman numerals are your friend; they tell you the charge of the metal ions that can have more than one oxidation state and thus form positive ions with different charges. Remember that Group IA, Group IIA, Al, Ag, Cd, & Zn are usually not written with a Roman numeral; you must know their charges. The most important thing to remember is that, the sum of the charges must add up to zero in order to form a neutral compound. The *crisscross method* is very useful—the charge on one ion becomes the subscript on the other. *If you use this method, you must always check to see that the subscripts are in their lowest whole number ratio!* Here are some examples:

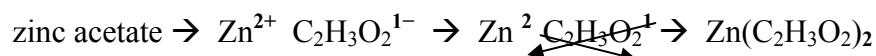
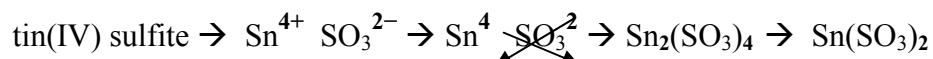
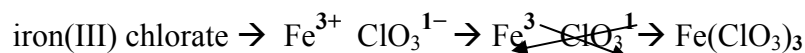
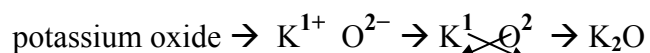

PURPOSE

To master the skill of writing and naming chemical formulas.

MATERIALS

Each lab group will need the following:

bag, zipper-lock, quart
copy of student formula manipulatives
scissors

PROCEDURE**Safety Alert**

Use care when handling scissors.

- Carefully cut out the models on Template 1. Group them by similar charge or oxidation state.
- Trace over the symbol and oxidation state of each element using colored markers and apply the color scheme below:

Color	Oxidation State
Blue	+1
Red	-1
Yellow	+2
Green	-2
Purple	+3
Pink	-3

- Notice how the models fit together. If an element has a +3 oxidation state, it requires three elements with a -1 oxidation state to create a complete compound and the subscripts would reflect a 1:3 ratio.
- Review the rules for naming acids and complete Table A on your student answer page. Use the models you created from Template 1 as needed. Supply either the acid's name or its formula to complete Table A.
- Review the rules for naming binary ionic **and** molecular compounds. Use the models you created from Template 1 as needed. Supply the compound's **formula and name** to complete Table C. If the charge or oxidation state is missing from the table, it is because you should already know them or be able to determine them due to their position in the periodic table.
- Carefully cut out the shapes on Template 2. Each carbon model has 4 inward notches. The model "bonds" found on Template 2 are for connecting the carbons. These shapes will be used to help you with organic compounds. There is no need to color them.
- Review the rules for naming organic hydrocarbons and alcohols. Use your models from Template 2 as needed. Fill in the missing formulas **and** names for each compound in Table B.

Chemical Nomenclature

Naming and Writing Chemical Formulas

All You Really Need to Know About Chemical Names and Formulas SUMMARIZED

In this flowchart, D and J in the general formula D_xJ_y can represent atoms, monatomic ions, or polyatomic ions.

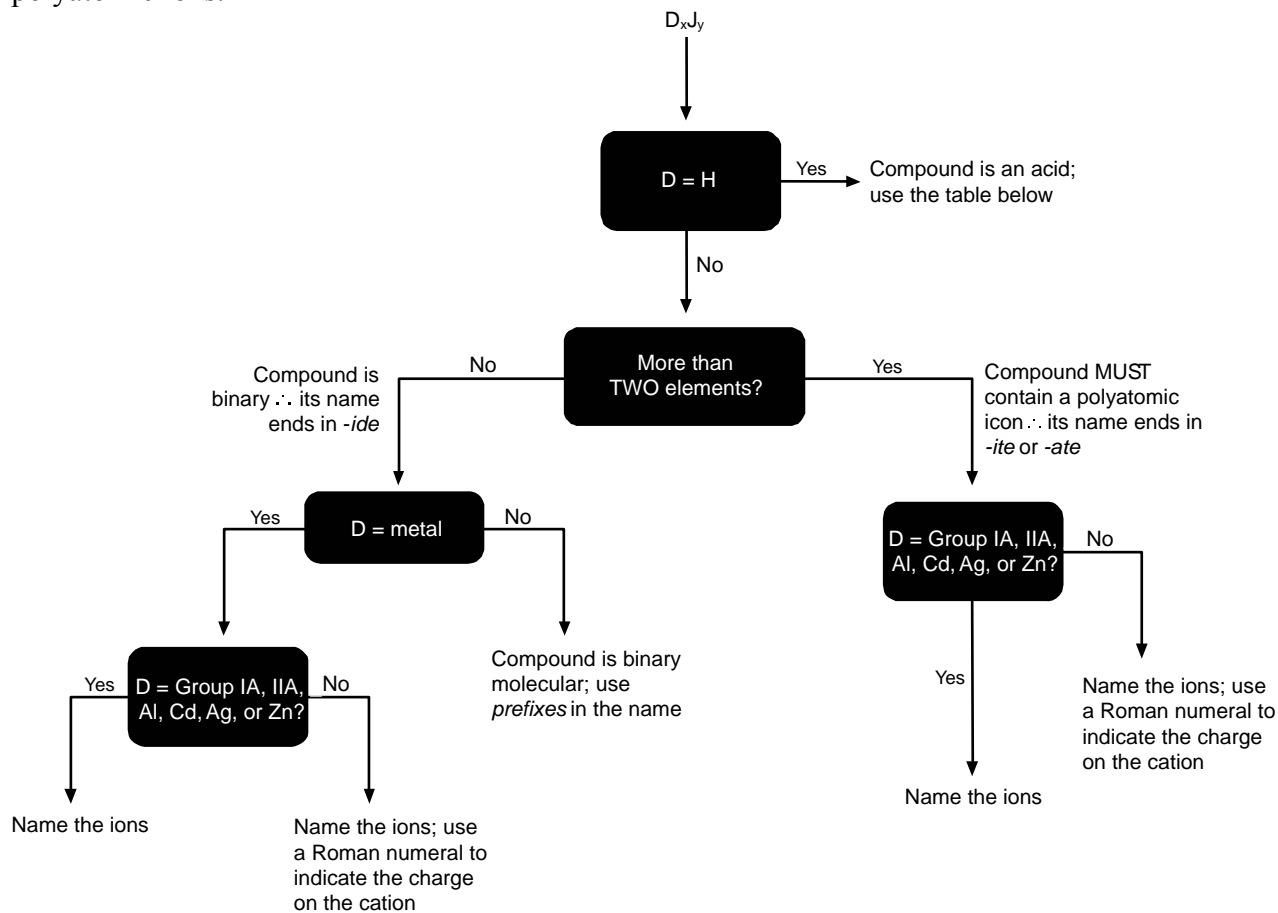

Naming Acids			
Anion ending	Example	Acid name	Example
-ide	S ²⁻ sulfide	Hydro-(stem)-ic acid	hydrosulfuric acid
-ite	SO ₃ ²⁻ sulfite	(stem)-ous acid	sulfurous acid
-ate	SO ₄ ²⁻ sulfate	(stem)-ic acid	sulfuric acid

CONCLUSION QUESTIONS

Table A	
Acid Formula	Acid Name
HCl	
	hypochlorous acid
	chlorous acid
	chloric acid
	perchloric acid (“hyperchloric” acid)
HNO ₃	
	hydrobromic acid
H ₃ PO ₄	
H ₃ PO ₃	
	hydrocyanic acid
HC ₂ H ₃ O ₂	
	carbonic acid
	hydroiodic acid
HF	

Table B

# of carbon atoms = n	prefix or stem	-ane C_nH_{2n+2}	-ene C_nH_{2n}	-yne C_nH_{2n-2}	-anol $C_nH_{2n+1}OH$
1	meth-		None here because you must have at least 2 carbons for multiple bonding		CH_3OH methanol
2	eth-				
3	prop-		C_3H_6 propene		
4	but-				
5	pent-	C_5H_{12} pentane			
6	hex-				
7	hept-				$C_7H_{15}OH$ heptanol
8	oct-			C_8H_{14} octyne	
9	non-				
10	dec-				

Table C

	Ag^+	Pb^{2+}	Cu^+	Ba^{2+}	NH_4^+	Al^{3+}	Mn^{2+}
N^{3-}							
O^{2-}							
Br^-							
S^{2-}							
SO_4^{2-}							
ClO_2^-							
PO_3^{3-}							

Template 1

NH_4^+	Pb^{2+}	Br^-
Mn^{2+}	Ag^+	Cl^-
Al^{3+}	H^+	NO_3^-
H^+	H^+	N^{3-}
H^+	H^+	O^{2-}
H^+	H^+	O^{2-}
H^+	Cu^+	S^{2-}
H^+	Ba^{2+}	S^{2-}
H^+		SO_4^{2-}

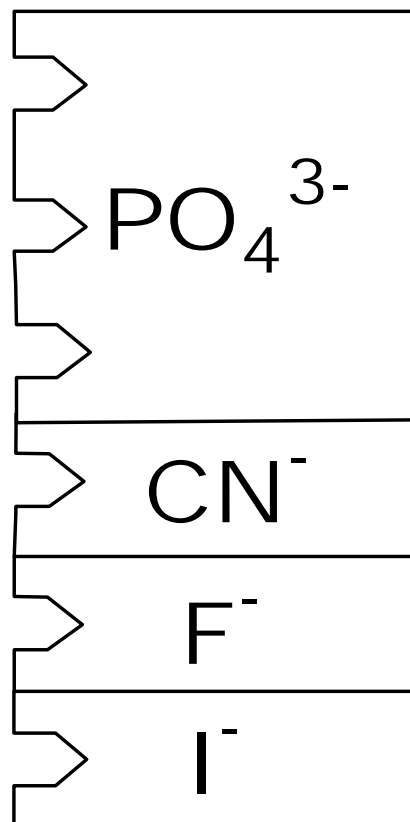
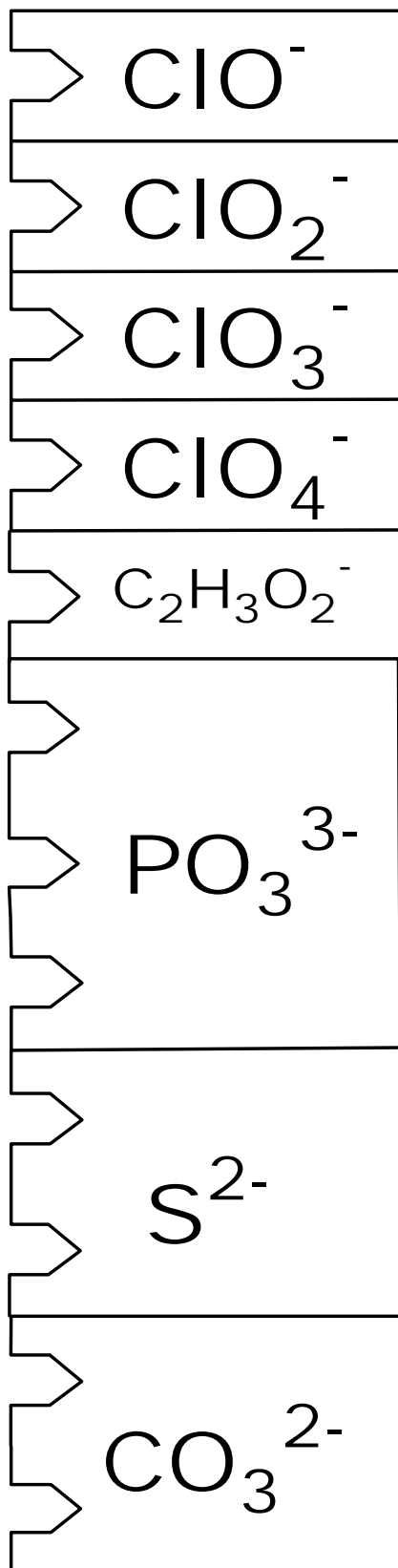

Template 2

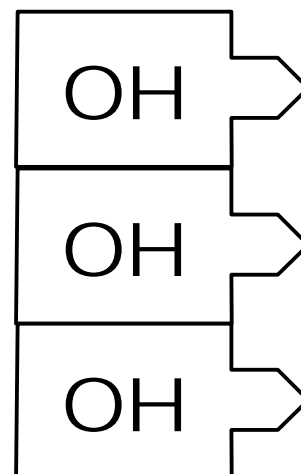
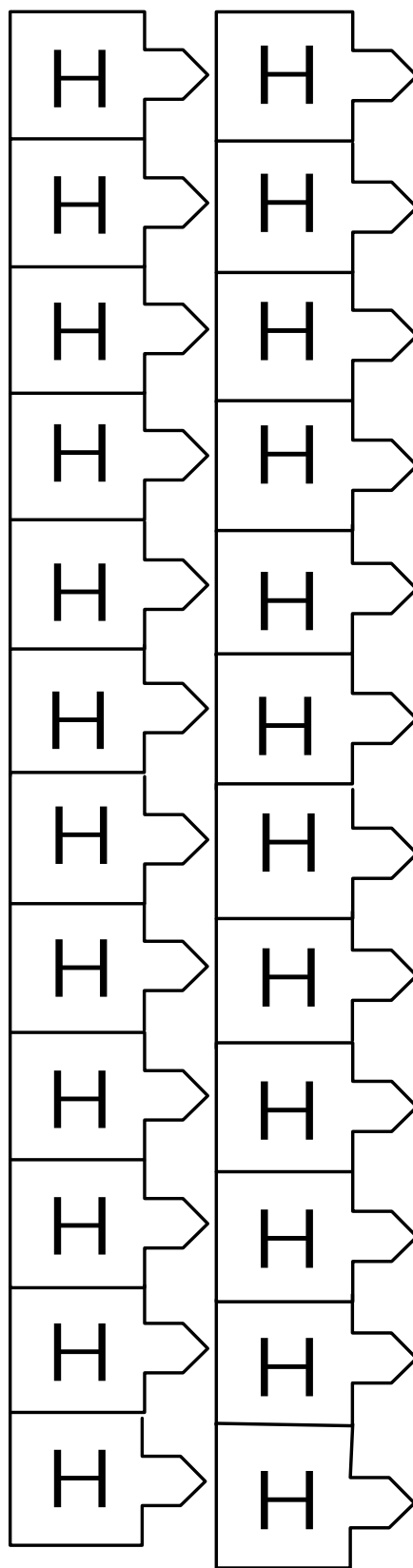
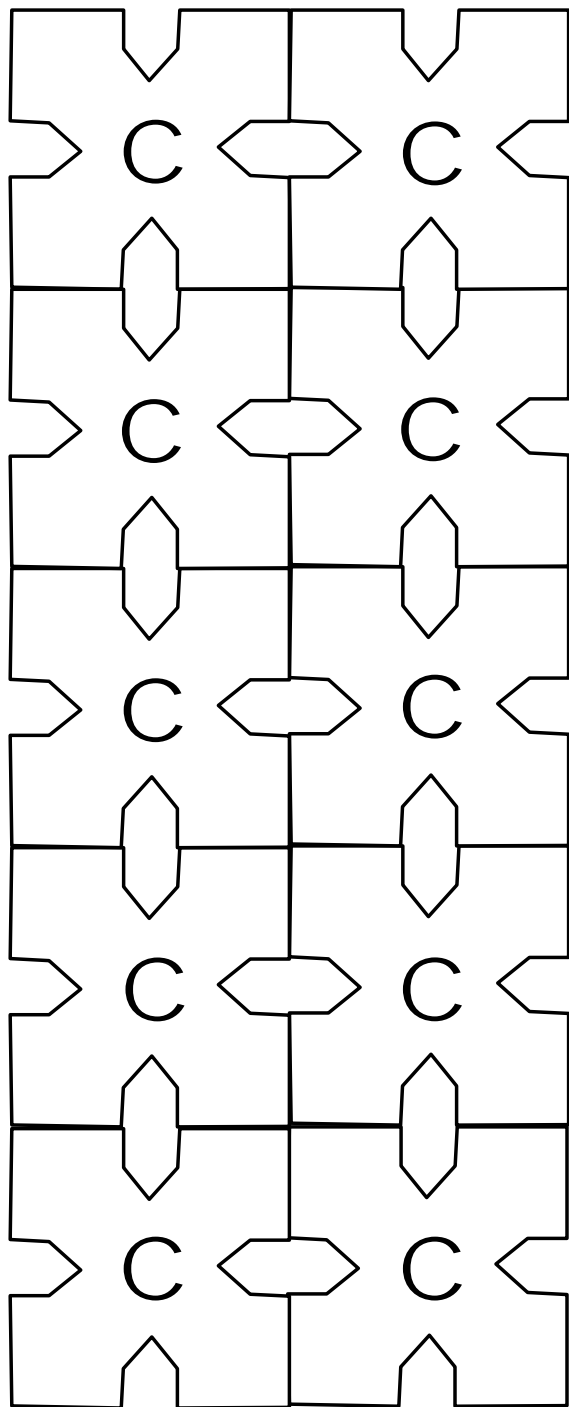

Use the models below as single, double and triple bonds for connecting carbons.
Remember, DO NOT allow C to have more than FOUR total bonds!

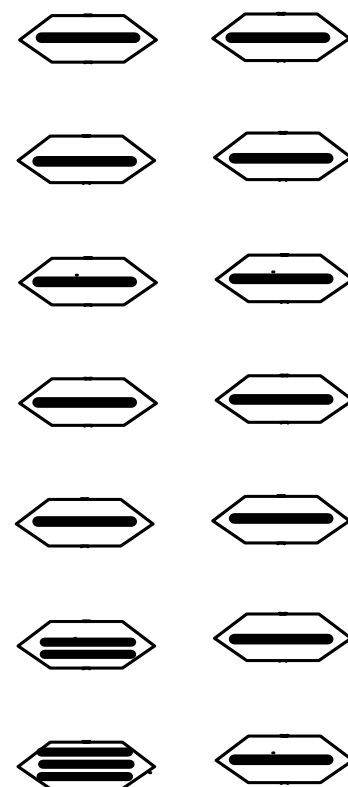

Elements for Student Memorization

The following are a list of elements that you are expected to know for the rest of the year. Start learning them now!!!!

Name	Symbol
aluminum	Al
antimony	Sb
argon	Ar
arsenic	As
barium	Ba
beryllium	Be
bismuth	Bi
boron	B
*bromine	Br
cadmium	Cd
calcium	Ca
carbon	C
cesium	Cs
*chlorine	Cl
chromium	Cr
cobalt	Co
copper	Cu
francium	Fr
*fluorine	F
gallium	Ga
germanium	Ge
gold	Au
helium	He
*hydrogen	H
indium	In
*iodine	I
iron	Fe
krypton	Kr
lead	Pb
lithium	Li
magnesium	Mg

Name	Symbol
manganese	Mn
mercury	Hg
neon	Ne
nickel	Ni
*nitrogen	N
*oxygen	O
palladium	Pd
phosphorus	P
platinum	Pt
plutonium	Pu
potassium	K
radium	Ra
radon	Rn
rubidium	Rb
scandium	Sc
selenium	Se
silicon	Si
silver	Ag
sodium	Na
strontium	Sr
sulfur	S
tellurium	Te
thallium	Tl
tin	Sn
titanium	Ti
tungsten	W
uranium	U
vanadium	V
xenon	Xe
zinc	Zn
zirconium	Zr

*In addition to the above you should know which elements are diatomics. These are elements that exist in pairs, never as single elements. When asked to write the symbol, a subscript 2 must be used. These are I₂, Br₂, Cl₂, F₂, O₂, N₂, and H₂. A useful mnemonic is **I** **B**ring **C**lay **F**or **O**ur **N**ew **H**ouse.